

R-LINE[®] TRACK

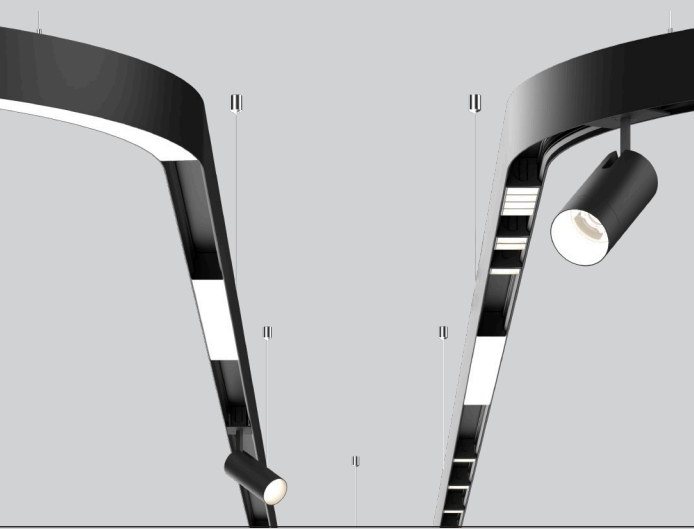

CERTIFICATIONS & COMPLIANCE



FEATURES

5 YEAR
limited
led warranty

CHANNEL



R1 R2 R3

PERFORMANCE

- Modular 48V track system
- Combine linear, curve, and track
- Patented technology
- Field cuttable track

CONFIGURATIONS



Linear Corner Curve

MOUNTING



Trimless Recessed Surface Suspended Indirect Suspended

INSET OPTIONS

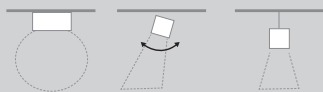

Opal Spotlight Decorative

Catalog Number Example

RLTR-R1-PDT-BLBL-48V-010V-1C-ST-02'

A B C D E F G I

A PRODUCT

R1 Track 1" track	R L T R-R 1
R2 Track 2" track	R L T R-R 2
R3 Track H track	R L T R-R 3

R3 track is only available as a pendant

B MOUNTING

Recessed Trimless	R T L
Surface Mount	S U R
Pendant Cable	P D T
Pendant Stem <i>coming soon</i>	S T M
Custom Mount	X X X

custom mount, please contact BASO

C HOUSING COLOR

Black RAL9005	B L _ _
White RAL9016	W H _ _
Custom RAL	X X _ _

custom RAL, please contact BASO

PENDANT HARDWARE COLOR

sub option: pendant cable or stem only

Black	_ _ B L
White	_ _ W H

None recessed or surface mount

power feed, stem & canopy cover only; AC cable & barrel mount come in silver

D VOLTAGE

48V low constant voltage	4 8 V
--------------------------	-------

remote driver required (see driver cutsheet)

E DIMMING

0-10V 1% dimming	0 1 0 V
------------------	---------

F CIRCUIT

1 Circuit 2x48V 1xPWM	1 C
2 Circuit 4x48V 2xPWM	2 C
4 Circuit 8x48V 4xPWM	4 C

4 circuit R3 track only; for EMC contact BASO

G SHAPE/PATTERN

Linear	S T
L-Shape (90°)	L S
□-Shape rectangular shape (90°)	R S
U-Shape (90°)	U S
Z-Shape (90°)	Z S
Wall to Ceiling (90°)	W C
Custom Pattern	C P

custom angles and patterns, please contact BASO

H CORNERS

No Corners	*
Mitered 90°	M 9 0
Curved Radius 18"/90°	R 1 8
Curved Radius 24"/90°	R 2 4
Curved Radius 36"/90°	R 3 6
Custom	X X

custom radius and angles, please contact BASO
*leave empty

I DIMENSIONS

2' 0" min. length	0 2'
4' 0"	0 4'
6' 0"	0 6'
8' 0"	0 8'

Shape / Pattern	_ _ x _ _ x _ _
Custom	_ _ ' _ _ "

custom patterns, please contact BASO

J FIELD CUT

Field Cuttable Track	F
----------------------	---

please see next page for limitations

K CCEA (optional)

CCEA Rated (Chicago Plenum)	C P
-----------------------------	-----

recessed and surface mount only

Optional Accessories

ships separately

L BLIND COVERS

Blind Cover 1" flush with R1 track	B 1
------------------------------------	-----

includes field cuttable blind cover (end to end)

+ TRACK WITH UPLIGHT

see R-Line Uplight cutsheet

DIMENSIONS

R1

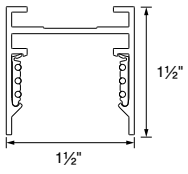

R2

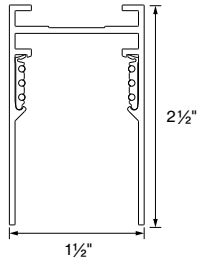

R3

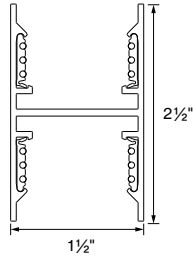

R1 (Recessed Trimless)

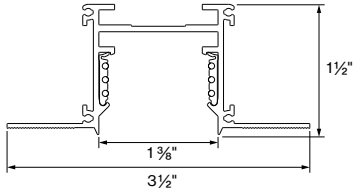

R2 (Recessed Trimless)

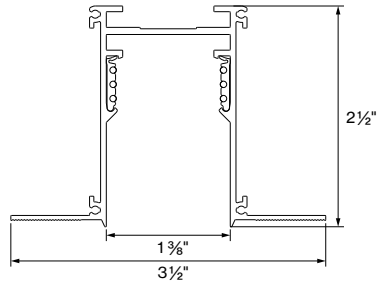

POWER FEED

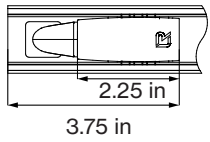

ELECTRICAL CONNECTOR

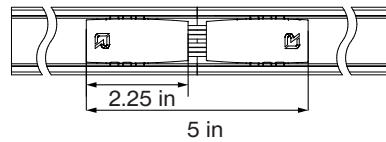

ELECTRICAL CONNECTOR

L-Configuration

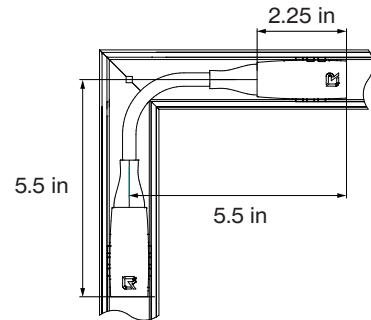

Insets cannot be placed on top of power feeds and electrical connectors.

ELECTRICAL CONNECTOR

X-Configuration

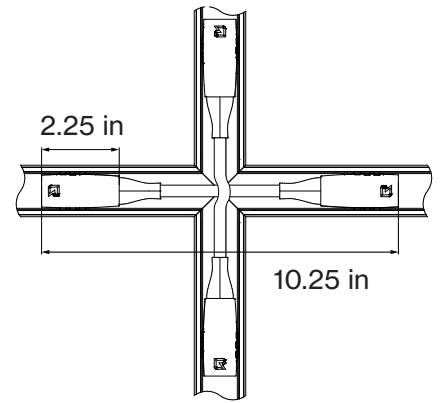
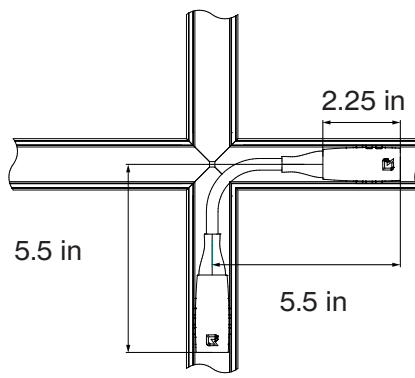
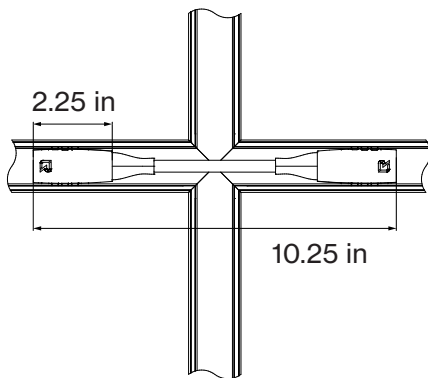

POWER TRACK CIRCUITRY

R1/R2

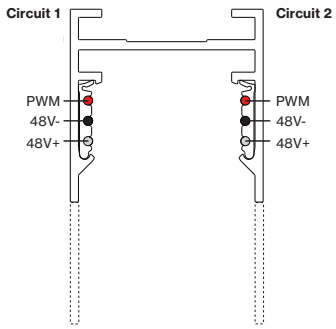

R3

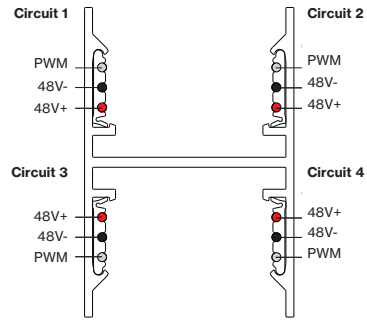

CIRCUIT DIAGRAM

R1/R2 Single Circuit

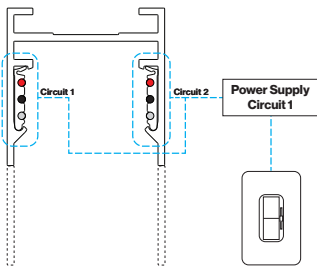

R1/R2 Two Circuit

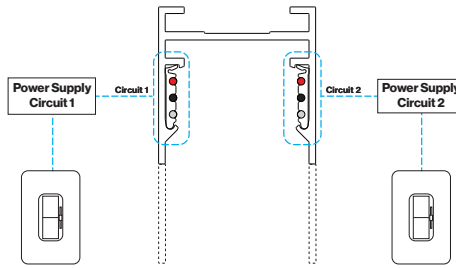

R3 Single Circuit

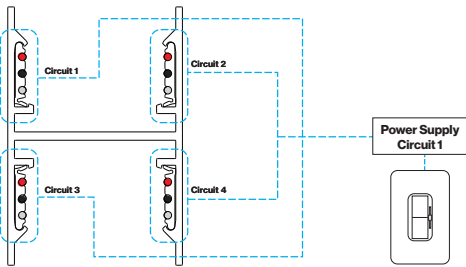

R1/R2 Two Circuit

